



FURNACE & ASSAY

— S U P P L I E S —

**50/84 Place Fusion Furnace, 240v
Fan Forced
Nat Gas or LPG**

Fuel Source:

NG

**Manufacturing
Date**

Electrical:

220-240V

Working Area

- 650mm Deep
- 1220mm Wide
- 350mm High

**Combustion
Chamber**

Volume:

0.499

Swept Volume:

0.526



Tel: +61 8 9399 9299

E-mail: info@fandasupplies.com

Website: fandasupplies.com/

Manual Index

System Overview	3-4
Safety Devices	5
Parts List	6-7
Installation Procedure	8
Operating Instructions	9
Warm up Procedure	10
Commissioning procedure	11-17
Gas Submission	18
Operational Flow Chart	19
Troubleshooting Guide	20-24
Electrical Schematic	25
Fuel Schematic	26
Maintenance	27-38
Contact Details	39

System Overview

Construction

Construction

- Base construction uses high-quality 100x 100 laser-cut plate
- Furnace body construction is durable 5mm laser-cut plate
- High quality refractory brick and insulation
- Base plates of all 4 legs for individual adjustment on uneven surfaces
- Bolt holes in base plates of all 4 legs for pneumatic door controls with foot pedal controller—available with an optional hand valve controller
- Pneumatic door controls with foot pedal controller—available with an optional hand valve controller

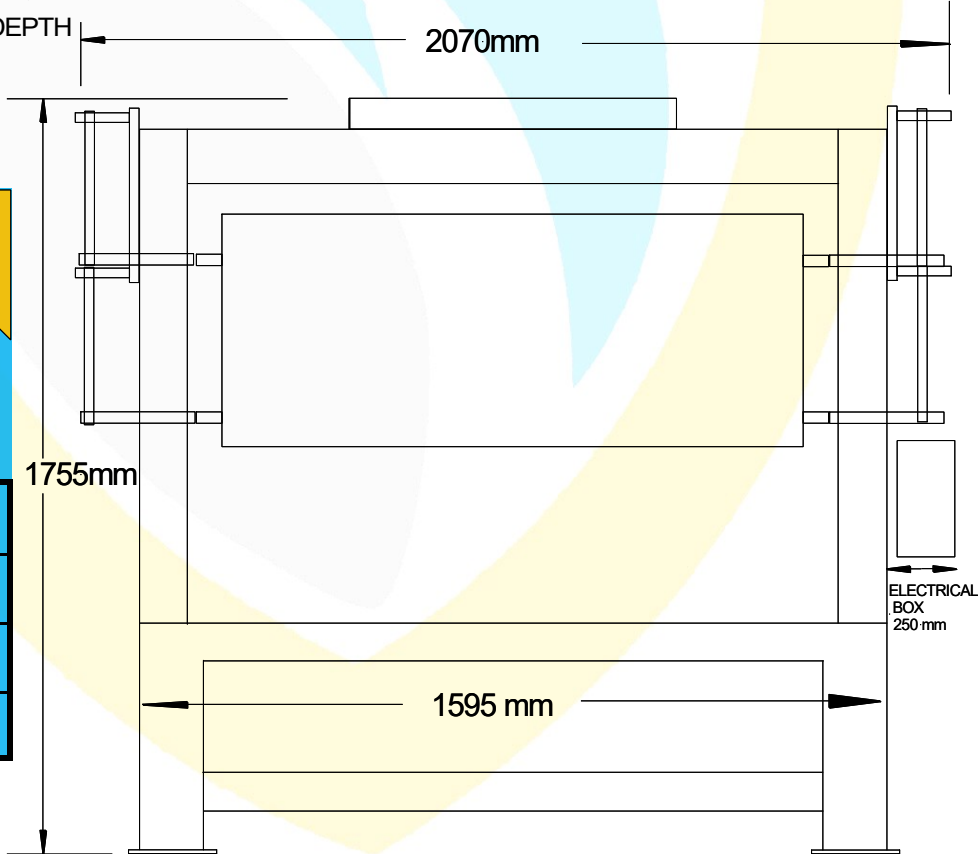
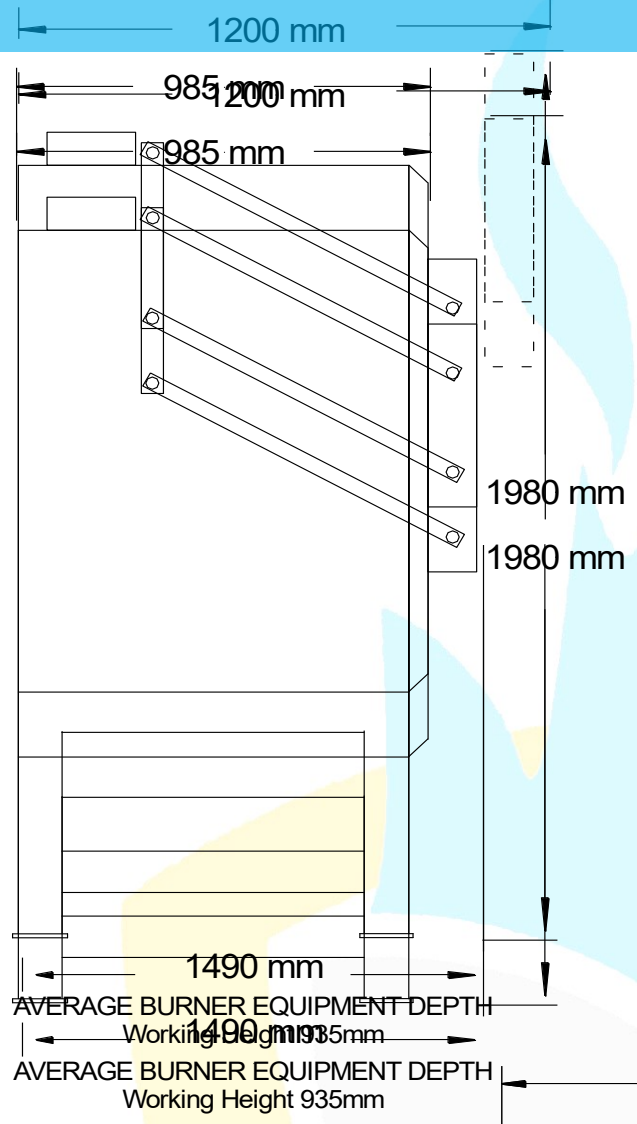

Shipping

- ISPM 15 Heat treated export crates

Length	2090mm
Width	1690mm
Height	2080mm
Weight	2200KG

Please note you will require a minimum of 1 metre clearance around the furnace.

* Dimensions are approximate only and may vary slightly with each furnace.

System Overview

System Overview:

This furnace has a fan forced dual burner system, with an automatic ignition system. It can be swapped between NG and LPG (propane) to suit varying site requirements, with just a few simple adjustments performed on-site involving a minimum of downtime and associated costs.

Temperature is monitored and modulated automatically by a Type K thermocouple system and Omron temperature controller, pre-set for a maximum temperature of 1200 degrees Celsius. This controller is simple to operate, and has a 2-level display (PV and SV), that shows actual temperature as well as the temperature the furnace is set to.

The door has a pneumatic ram opening system with an easy to use foot pedal control.

Power Requirements	
• Volts	240V
• Phase	1
• Kilowatts	1
Fuel Type	Natural Gas or LPG
Gas Consumption	540MJ Per Hour
Operating Pressure	3.5 KPA
Gas Pressure Requirements	
Minimum Inlet Pressure	3.5KPA
Maximum Inlet Pressure	7KPA

Safety Devices Installed

UV Flame Detection

Low Gas Pressure Detection

Air Pressure Switch

CPI Switch

Safety Devices

The Safety Features on this Furnace are:

UV FLAME DETECTION:

1/. Installed is a UV flame detection unit which monitors burner flame. It checks that there is no flame present at start up of furnace. If there is then furnace will not start. This will only happen if the unit can detect either residual flame inside furnace or flame from another source.

2/. During second purge cycle and after pilot ignition it will do a check 5 seconds after ignition. If no flame detected then controller will lock out. Also if UV flame detector is faulty controller will lock out.

3/. A UV amp meter is fitted to the front of the electrical box to monitor the performance of the UV flame detector. Good flame detection will indicate between 0.5-0.8 m amps. If the reading falls below 0.2 m amps then either the flame detector unit is aging and needs replacing or the holder that houses the unit needs correct alignment with the flame.

LOW GAS PRESSURE DETECTION.

1/. If gas pressure falls below set point on guage the fame will go out and the blower will continue running for a complete purge cycle. This is to exhaust any built up combustion gases .

2/. The furnace will not start if there is low gas pressure supply.

NOTE: The switch will need to be reset if low pressure has been experienced.

HIGH GAS PRESSURE DETECTION. (optional extra)

1/. If gas pressure Rises over a set point on guage the fame will go out and the blower will continue running for a complete purge cycle. This is to exhaust any built up combustion gases .

2/. The furnace will not start if there is High gas pressure supply.

NOTE: The switch will need to be reset if High pressure has been experienced.

AIR PRESSURE SWITCH:

1/. If air pressure falls below set point on guage then the furnace will shut down. This will lock out burner control on alarm. There is a first pressure check during the second purge cycle of start up and if lock-out occurs the controller stops on P.

NOTE: If lockout occurs then the blower motor or system to burner may need cleaning.

CPI SWITCH:

A switch is installed in the gas valve train to detect gas flow during operation. If gas is detected passing through gas valve train before start up of furnace then controller will not operate.

NOTE: This will not lock burner controller out but will not allow controller to continue with cycle

OVER TEMPERATURE CONTROLLER: (optional extra)

1/. The furnace is fitted with a over temperature controller and will shut furnace down if temperature goes over the set point on the controller. Also if the thermocouple for the controller is faulty the furnace will shut down. This is indicated by an sEer error reading on the controller .

Parts List for FAS-120-NG2

50/84 Place Fusion Furnace, Fan Forced 240v Gas

Recommended 12 Months Consumables

FAS Part#	FAS Description	Qty
FAS-305	Floor Tile 610x650x25mm	12
FAS-603	Ceramic Anchor, (Complete) 3"	30
FAS-605	Thermocouple Element, type K. 310mm	6
FAS-611	U.V. Cell Flame Detector QRA.2	4
FAS-673	Thermocouple Inconel Sheath (No Sheath Adaptor)	6
FAS-803	Isowool Blanket (Kaowool) 160kg x 25mm	1
FAS-1008	Refractory Mortar 2 KG	1

Recommended Critical Spare Parts

FAS Part#	FAS Description	Qty
FAS-609	Thermocouple 1/2" Head	1
FAS-613	Relay, Omron Ly2N	1
FAS-616	Burner Controller, LFL1.1635	1
FAS-618	Flame Relay, LFE.10	1
FAS-620A	Dual Ignition Transformer TQO31A2750	1
FAS-625	DIN Plug Solenoid	1
FAS-627	Ignition Lead (Copper Cord)	3
FAS-627A	Ignition Boot and Connector	2
FAS-639	Igniter Spark Plug UY6	2
FAS-648	Temperature Controller, Omron E5CZ R2MTC-500 (Relay)	1
FAS-665	Blower Motor Air Hose	2
FAS-666	Manometer, Liquid Filled	1

Recommended Spare Parts

FAS Part#	FAS Description	Qty
FAS-84D	50/84PFF Door, factory lined (No Hinges or pins)	1
FAS-511	Contactora, ABB A12-30-10 *240V*	1
FAS-517	Relay Overload 7-10A	1
FAS-608	Thermocouple Wire	2
FAS-610	Thermocouple Sheath Adapter	1
FAS-612	U.V. Ammeter 0-1Ma 48x48mm	1
FAS-641	Gas Pressure Switch DG50N	1
FAS-642	Air Pressure Switch DG10U	1
FAS-654	Air Hose, Double Insulated	4
FAS-657	Foot Pedal, Festo	1
FAS-663	Blower Motor Assembly 240v	1
FAS-802	Isowool Blanket (Kaowool) 128kg x 50mm	2

Parts List for FAS-120-LPG2

50/84 Place Fusion Furnace, Fan Forced 240v Gas

Associated Spare Parts

FAS Part#	FAS Description
FAS-120-SHL	50/84PFF New Body and Bricks
FAS-120-BRN-LPG2	50/84PFF Burner Equipment LPG Fan Forced 240v
FAS-120-DHP	50/84PFF Door and Hinge with Pneumatics
FAS-120-BKT	50/84PFF Refractory Reline Kit
FAS-600	Thermocouple Fusion Complete with Sheath Assembly
FAS-628	Toggle Switch (on/off, high/low)
FAS-640	Gas Pilot Burner
FAS-645	Natural Gas Valve Train
FAS-655	Pneumatic Cylinder
FAS-656	Pneumatic Cylinder set
FAS-658	Pneumatic Foot Kit (inc cylinders, foot pedal, mounting brackets and fittings)
FAS-659	Pneumatic Regulator
FAS-669	Regulator OPSO
FAS-670	5AMP Control Fuse
FAS-673A	Thermocouple Inconel Sheath and Sheath Adaptor
FAS-674	Plug in 6mm Air Fitting
FAS-681	Surge Protector *240V*
FAS-801	Isowool Blanket (Kaowool) 128kg x 25mm
FAS-1001	Flue Block - Large 50PFF
FAS-1002	Flue Block - Small
FAS-1003	Burner Port Square Hole 230x250mm
FAS-1004	Refractory Mortar 25kg Drum
FAS-1005	Ceramic Paper, 3mm x 610mm x 15m Roll
FAS-1006	Refractory Castable 25kg Bag
FAS-1007	Refractory Mortar 1KG

Installation Procedure

- *Unpack furnace from crate and store in dry area. The furnace usually has timber supports installed inside for transport. Remove before operation.**
- *Remove Furnace Manual from inside of furnace chamber.**
- *Furnace requires a min of 1 metre space around it to carry out maintenance / repairs.**
- *Install fuel supply. This must be carried out by a qualified technical person.**
- *Refer to furnace gas requirements to size inlet line correctly.**
- *For door operation air is required to run the pneumatics. Connect air supply to the filter on the furnace.**
- *Electrical box is fitted with 3 core flex. If power socket is available connect correct type plug and turn on. If not then an electrician is to either install correct socket or hard wire furnace to power supply.**
- *NOTE THIS FURNACE USES SINGLE PHASE POWER WITH A NEUTRAL WIRE AND EARTH.**
- *BEFORE STARTING CHECK THAT ALL EXHAUST DUCTING IS IN PLACE.**

Operating Instructions

FURNACE START UP

1. TURN ON **GAS SUPPLY**.
2. TURN ON **MAIN SWITCH**.
3. SET REQUIRED TEMPERATURE. (See warm up procedure for instructions on starting a cold furnace)
4. TURN ON **BURNER SWITCH**. (Burners will take approximately 70 seconds to ignite)
5. SET **HIGH \ LOW SWITCH TO HIGH**.

(Burners will modulate between High and Low fire to maintain the set temperature.)

FURNACE SHUTDOWN

1. TURN **BURNER SWITCH OFF**.
2. ISOLATE GAS SUPPLY.

Warm-Up Procedure

First Time Start Up

A new furnace will still have moisture trapped within the roof and requires curing over a period of a few days to strengthen the refractory.

Always start on low fire and run for half hour on then half hour off. Continue this procedure for a minimum. of 6 hours. Once completed then leave on low fire for at least 24 hours.

Keep a close eye on any cracks that may develop on front of refractory indicated by moisture seeping through refractory. If you see this then maintain temperature until moisture clears.

After around 30 hours you will notice that the furnace temperature is running around 650degC. You can now turn furnace to high fire and set the controller 100degC above the real temperature. Let the furnace modulate on this temperature for an additional 1hour.

Keep a close eye on any cracks that may develop on front of refractory indicated by moisture seeping through refractory. If you see this then maintain temperature until moisture clears.

Increase set point in 100degC increments every hour until desired temperature is reached.

Starting a Cold Furnace

When furnace has been shut down for a period of time (2-3 days) then you will need to start up the furnace slowly.

1. Leave on low fire for minimum of one hour then increase set point to 750Degc.
2. Leave on 750Degc for minimum of one hour.
3. Continue to increase to required temperature.

Commissioning Procedure

50/84 Place Fusion Furnace, 240v Fan Forced Nat Gas or LPG Electrical Box Layout

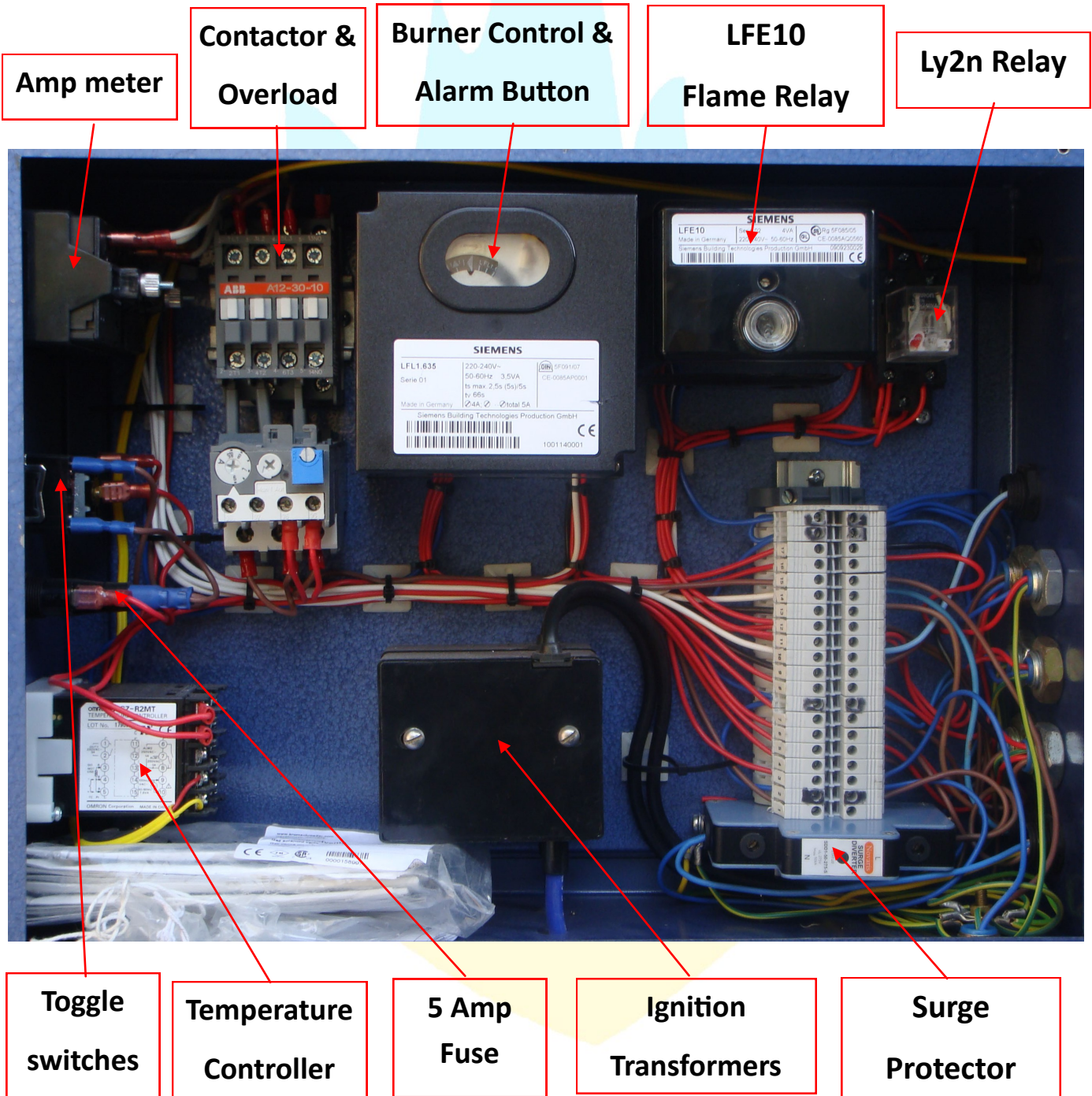

Commissioning Procedure (2)

50/84 Place Fusion Furnace, 240v Fan Forced

Nat Gas or LPG

Burner Equipment overview

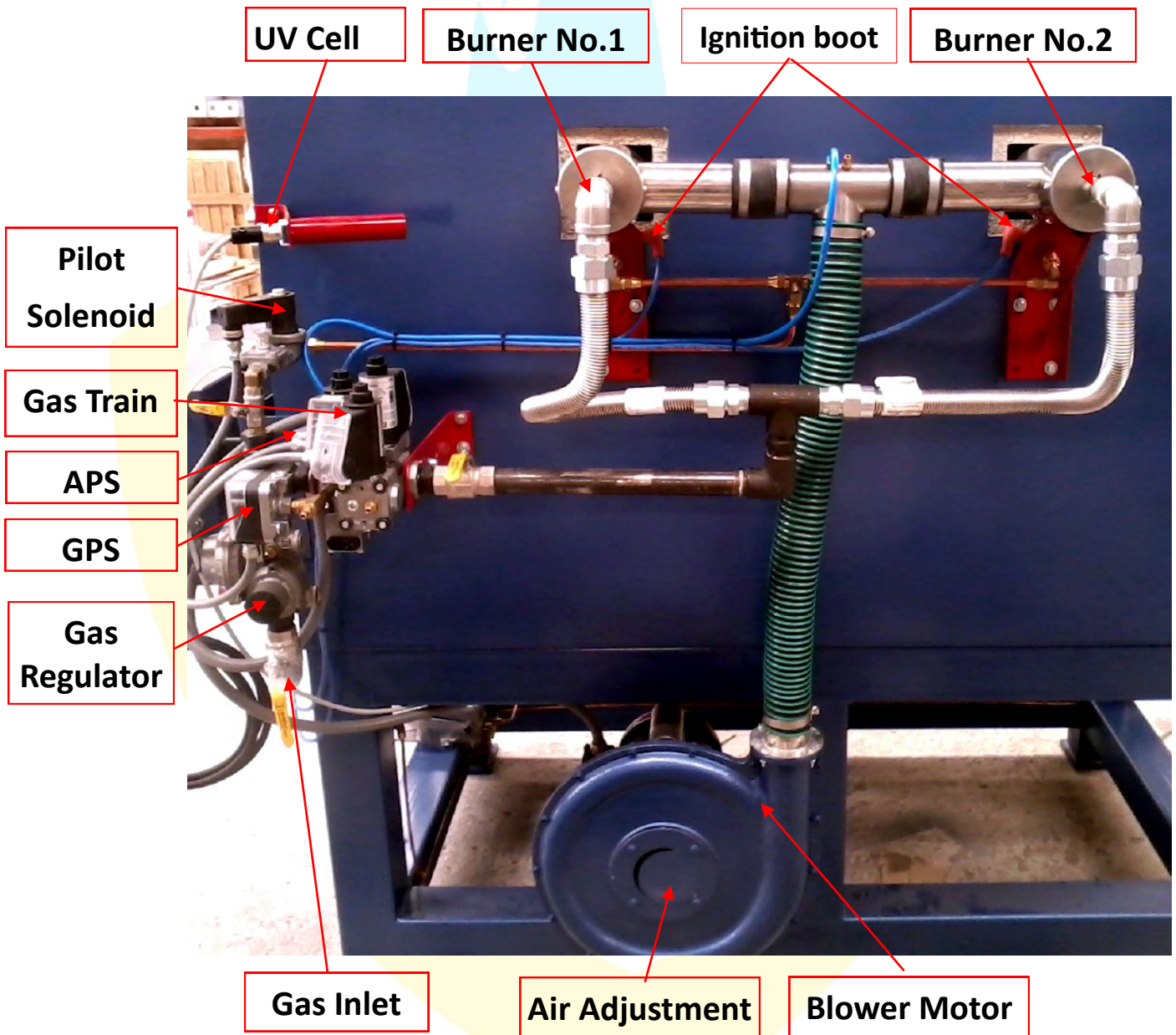

Commissioning Procedure (3)

50/84 Place Fusion Furnace, 240v Fan Forced

Nat Gas or LPG

Pressure Check points

Regulated
Pressure
Test point

Pilot Test point

Air pressure
Test point

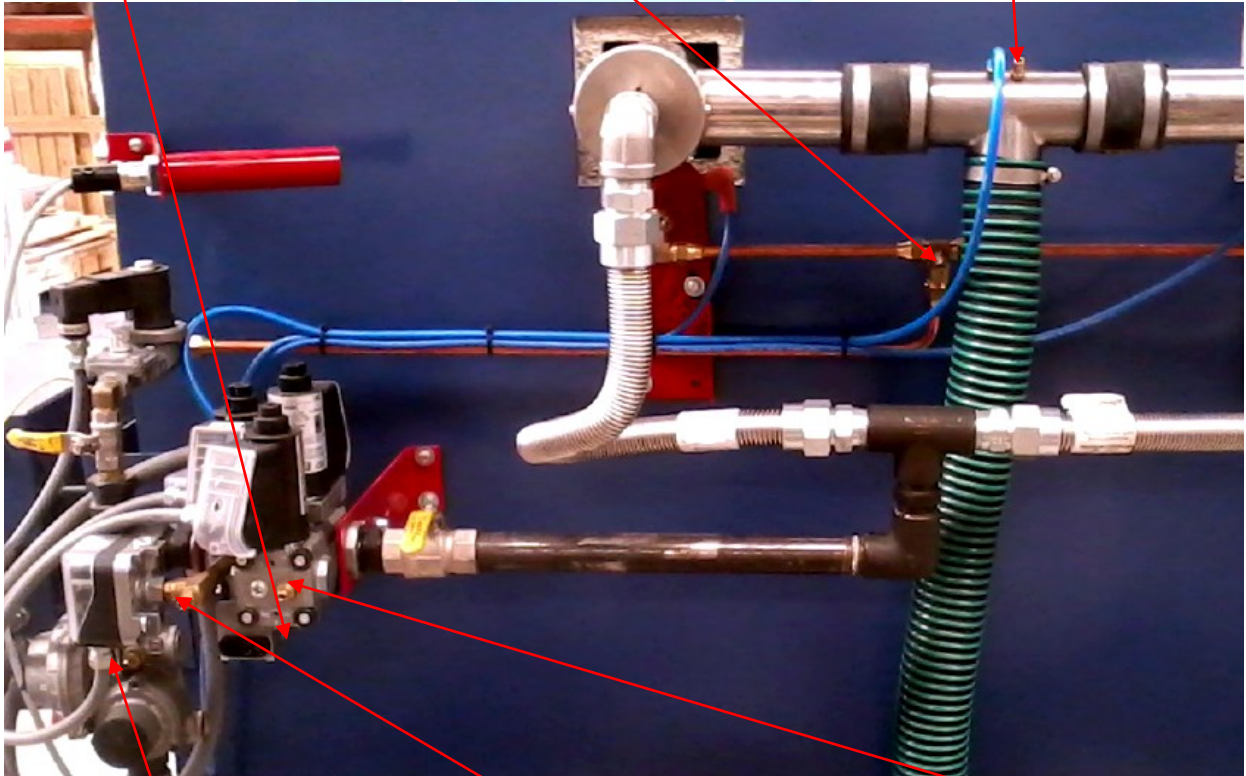

Gas pressure
switch test point

Supply Pressure
Test point

Burner Head
Pressure Test
Point

Commissioning Procedure (4)

Once power and gas lines have been installed

1. Purge gas line of air
2. Turn gas on slowly
3. Check static supply pressure.

Undo Gas Pressure switch test point and attach tube from manometer (you will need a manometer scaled to min 5KPA)

location of gas pressure switch test point

Take reading max 3.5KPA (14"WC) min 3.0KPA (12"WC)



4. Check for leaks (use soapy water)
5. Check supply pressure (3.5KPA)
6. Turn power on and make sure furnace is set to Low fire.

(Toggle switches located on front of electrical box)

Amp Meter

High/Low Switch

On/Off Switch

Temperature Controller

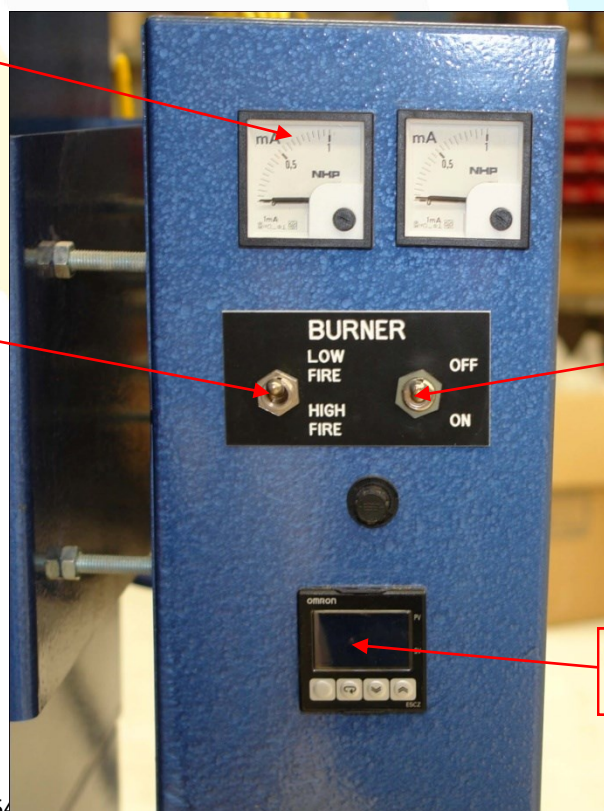

Commissioning Procedure (5)

7. Check all gas Ball Valves are in the open position
8. Push burner control button if alarm light is on.
9. Reset Gas Pressure Switch (push button on GPS)
10. Wait for Burner control to go through its stages

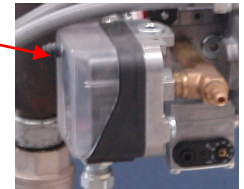

NOTE: Each time the furnace is started it goes through a pre purge first then on to a full purge of 63 seconds. Once this purge has finished ignition will start at pilot burners followed by solenoid opening and then flame on the pilot. Check pilot gas flow (2.8kpa)

If the furnace will not run through its start up sequence and the gas pressure switch has been reset, and Burner Controller alarm light is not on, the supply pressure may be too low (increase to 3.5KPA) or lower the set point value on the Gas pressure switch.

WARNING: RUNNING GAS PRESSURE TOO LOW WILL CAUSE ERRATIC FLAME.

11. Check the air pressure before the furnace completes its start-up. Air pressure should be around 0.7Kpa. This can change from furnace to furnace. Once furnace is running set air to suit flame using flue gas analyser. If air pressure is too low then the flame may burn back. If too high then the pilot may blow out

NOTE: If reading is not as it should be turn off power switch, restart and make adjustments. Do this until correct reading is obtained.

If you do not believe you are getting an accurate reading from this test point, take the reading off the Air pressure switch test point. Use Slide on blower to adjust air pressure

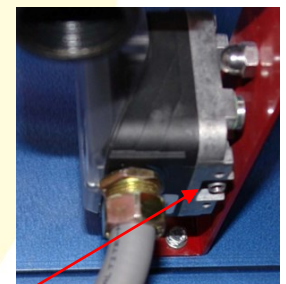

12. Spark plug clicks over, Pilot Solenoid Opens and Pilot flame established, UV detection, main valve opens and furnace starts on low fire.

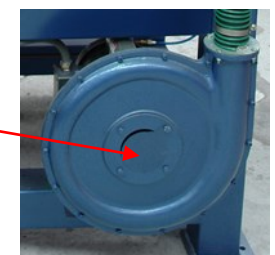

NOTE: You should regularly check UV Amp meters for a strong signal at start-up. Between 0.4 and 0.7mA is ideal. A low reading can be caused by UV Holders not being positioned correctly to see flame, or if the UV is faulty or dirty.

Commissioning Procedure (6)

13. Check U/V cells are working correctly:

Put hand over right UV cell

(Right burner should shut off, left burner should stay lit)

Put hand over left UV Cell

(Furnace should Alarm out)

14. Restart furnace

15. Let Furnace warm up slightly, about 300 deg c.

(If the furnace is cold it may have issues switching to high fire.)

16. Turn to hi fire and put temperature above set point on temperature controller. Furnace should swap to low fire when it hits set temperature

17. Check amp meter reading, should be on 0.4m/amp or better

18. Take Pressure readings.

GAS PRESSURE	SUPPLY	REGULATED	BURNER HEAD
STATIC kpa
LOW FIRE kpa
HIGH FIRE kpa
PILOTkpa
AIR PRESSkpa

19. [Follow Warm up Procedure on Page 10](#)

Commissioning Procedure (7)

20. Once you have taken all pressure readings then do a flue gas analysis.

O2 should be around 4 to 5.5% on high fire. If not then adjust air pressure to obtain. It is best to conduct testing above 750deg C

When a good burner flame is established check gas flow to furnace.

Ideal flow is 13m3/hr.

Adjust high fire pressure to reach this flow. Keep an eye on burner flame, you may have to adjust air flow to keep stable flame. Once flow is obtained then redo flue gas analysis to check that O2 is still OK.

Note: The only place to check gas flow is at the supply meter.

Low Fire Adjustment

High Fire Adjustment

Regulated Pressure Test Point

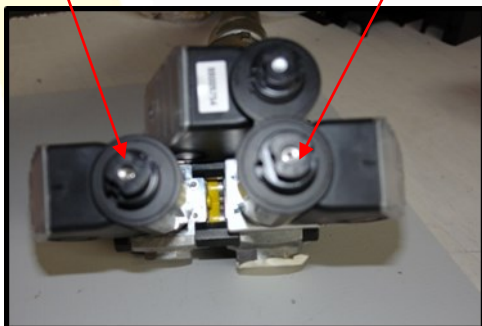

COMBUSTION	CO2%	O2%	CO ppm
START GAS
LOW FIRE
HIGH FIRE

Gas Submission

50/84 Place Fusion Furnace, Fan Forced 240v NG/LPG

<u>FUEL:</u>	Nat Gas or LPG
<u>BURNER:</u>	2 x FAS MODEL NG burner
<u>GAS RATE per burner:</u>	HIGH FIRE: 6.5 M3/HR LOW FIRE: 3.4 M3/HR PILOT : 0.2 M3/HR
<u>AIR FLOW:</u>	FIXED AT 143 M3/HR
<u>COMBUSTION CHAMBER VOLUME:</u>	0.499 M3
<u>TOTAL SWEEP VOLUME:</u>	0.526 M3
<u>PRE-PURGE TIME:</u>	$\frac{4 * 0.526 * 3600}{143} = 53 \text{ sec}$
<u>ACTUAL PREPURGE TIME:</u>	60 SECONDS (proved)
<u>START GAS:</u>	$\frac{0.2 \text{m}^3/\text{hr} * 100}{143 \text{m}^3/\text{hr Air}} = 0.13 \% \text{ LEL}$
CALCULATION	
<u>GAS PRESSURE AT BURNER HEAD:</u>	<u>HIGH FIRE:</u> NG: 0.85 Kpa LPG: 0.65 Kpa <u>LOW FIRE:</u> NG: 0.30 Kpa LPG: 0.30 Kpa
<u>AIR PRESSURE AT BURNER HEAD:</u>	0.7 Kpa FIXED

50/84 LPG Fusion Furnace Operational Flow Chart

50 Place LPG/ Nat Gas Fusion Furnace

This furnace is a dual fuel furnace and depending on the type of gas used settings will vary from LPG to Nat Gas. However the operation is the same for both fuels.

Power on via ON/OFF switch →

Pre purge cycle → Main purge cycle → ignition Transformer engages →

Pilot solenoid opens → Pilot flame established →

After 5 sec UV flame detection → Main Valve and Low fire valve open
if additional temperature required high fire valve opens.

Note:

The Temperature Controller only controls the High fire Solenoid.

The LFL1.635 Burner Controller supervises start up and any safety devices installed.

Trouble Shooting

By knowing the start up cycle of the furnace, you can isolate any problems that may arise. Also by setting up an operating register (weekly check sheet) you can monitor the operation of your furnace.

Keeping these records will assist in isolating any problems you are experiencing with the furnace. E.g., any changes in one or more of these readings will be your first indication that something may be wrong. Have a look at the problems below and the possible causes:

A) High/Low Fire Pressures are Decreasing.

This will tell you that something may be blocking up before the pressure gauge, or gas filter.

B) High/Low Pressures are Increasing.

This will tell you that the burner nozzle or gas filter needs cleaning.

C) The UV Reading on the Amp meters are decreasing.

You may need to check the alignment of the UV Cells; there may be a build up of dust on the globe of the UV cells, or the cell itself may be wearing out.

Other checks will also assist in the efficient operation of the Furnace.

Clean Burner equipment: - Dirt acts as an insulator, causing motors and solenoid coils to heat up. If this is left too long, eventually your equipment will fail.

Check Flues:- Blocked flues are the biggest cause of furnace break-down. Left unchecked, the operation of the furnace will quickly deteriorate. Some signs of blocked flues are:

- A) Flame shooting out of the top of the furnace.
- B) Flame licking outside of rear burners.
- C) Flame coming out of the door.

Operational Troubleshooting Flow Chart

Power On

Pre Purge Cycle

No power:

- Not plugged in
- Blown control fuse
- Surge Protector faulty

Pre Purge

Main Purge

Furnace dose not start Pre Purge Cycle:

- Gas Pressure switch has been tripped
 - Reset Gas Pressure Switch
 - Check Supply Pressure
 - Check for any gas leaks
 - Check Test points are shut
- CPI Switch Tripped
 - Check Gas Pressure
 - Pressure test for leaks using regulated pressure test point
- Burner Controller Alarmed out → Reset burner controller

Main Purge → Ignition Pilot Solenoid Opens

Blower Motor does not start in main purge cycle

- Relay Overload has been tripped → Reset Relay Overload
- Incorrect Single phase power supply → Check Single Phase Power is correct.

Furnace stops mid Main Purge with LFL controller alarmed out:

- Air pressure switch has been tripped
 - Check Air pressure reading
 - Clean fan housing and motor (compressed air)
 - Check for blockages in fan hose
 - Check for blockage in APS feed/fitting
 - Check for holes in hoses and feeds
 - Check APS Setting
- Uv Cell detecting a strong light source or flame:
 - Check Alignment of Uv Cell
 - Check for faulty UV Cell

Pilot Solenoid Opens → Ignition Transformer Engages → Pilot flame established

Ignition transformer does not engage:

- Faulty/ dirty spark plug → Clean or replace
- Faulty Boot or Connector → Repair
- Damaged Ignition cord → Replace
- Faulty Transformer → Replace

No Flame:

- Faulty/Blocked Solenoid → Replace/ Clean
- Gas Bottle Empty or frozen → Check at test point for flow. Change/fill bottle
- Low gas pressure → Check supply pressure at test point. Must be 5KPA.
→ Check Regulator has not tripped on over pressure.
- Blocked Pilot Burner → Remove and Clean
- Gas Lines not purged → Purge gas line of air

Pilot Flame Established → UV Flame detection

Pilot Flame Ignites but goes out:

- Ignites for 5 seconds and goes out → Check Uv Cell alignment to pilot flame
→ Check Uv Cell Globe for dust build up
→ Check Uv wiring is not damaged/incorrect
→ Replace Uv Cell, may be faulty
- Low or high Pilot Gas Pressure → Check pilot gas pressure
→ Set Pilot pressure to Min 1Kpa Max 2.8Kpa

UV flame detection → Main Valve and Low fire valve open → Flame Established

No Flame

- Ball valve is closed → Check all ball valves are in the open position
- Low gas pressure → Check supply pressure
→ Check Burner head pressure
- Low or main Valve not opening → Check for faults or blockages in valve

Flame goes out

- Gas pressure too high or low → Check supply pressure
→ Check Burner head pressure
→ Check for air or gas blockages in burners
- Uv Cell not detecting Flame → Check Uv Cell alignment to pilot flame
→ Check Uv Cell globe for dust build up
→ Check Uv wiring is not damaged/incorrect
→ Replace Uv Cell, may be faulty
- Frozen Pipes or bottle → Check lines and or bottle

Erratic flame

- Air pressure not correct → Clean fan housing and motor (compressed air)
→ Check for blockages in fan hose
→ Check for blockage in APS feed/fitting
→ Check for holes in hoses and feeds
→ Do flue gas analysis to adjust pressure
→ Check APS Setting
- Burner head pressure not correct → Check pressure reading
→ Do flue gas analysis to adjust pressure

NOTE: The Temperature Controller regulates high/low flame.

Flame is going out when switches to high fire

- Gas pressure set too high → Check high fire burner head pressure
- Furnace just started and is still cold → Let furnace heat up on low fire for half hour.

If not going to high flame:

- Temperature controller set too low → Check that set point is correct required temperature and is above actual reading.
- SEER Error shown on Temperature controller → Check Thermocouple – Replace
→ Thermocouple wire connections
- High Fire not set → Do flue gas analysis to adjust pressure
- High Fire Solenoid not opening → Check for blockages/ replace solenoid
- Not enough gas pressure → Check Gas Supply

Flame becoming erratic or shutting down when other gas equipment switched on

- Incorrect pipe sizing → Check sizing
- Not enough supply pressure → Check pressure for lab

Flame burning back from burner port

- Furnace flues blocked → Check and clean (Maintenance section Pg.28 onwards)
- Burner incorrectly aligned with Burner Port → Check and reposition

Flames coming out of Flues, side of Door

- Furnace Flues blocked → Check and clean (Maintenance section Pg.28 onwards)

Furnace not getting to temperature

- Pressure readings incorrect → Check Pressure readings and clean burner equipment
- High Fire not set correctly → Do flue gas analysis to adjust pressures
- Flue Gas is connected to Extraction system → Vent Flue gas direct to atmosphere

Refer to operational log book for normal High/Low settings

Electrical Schematic

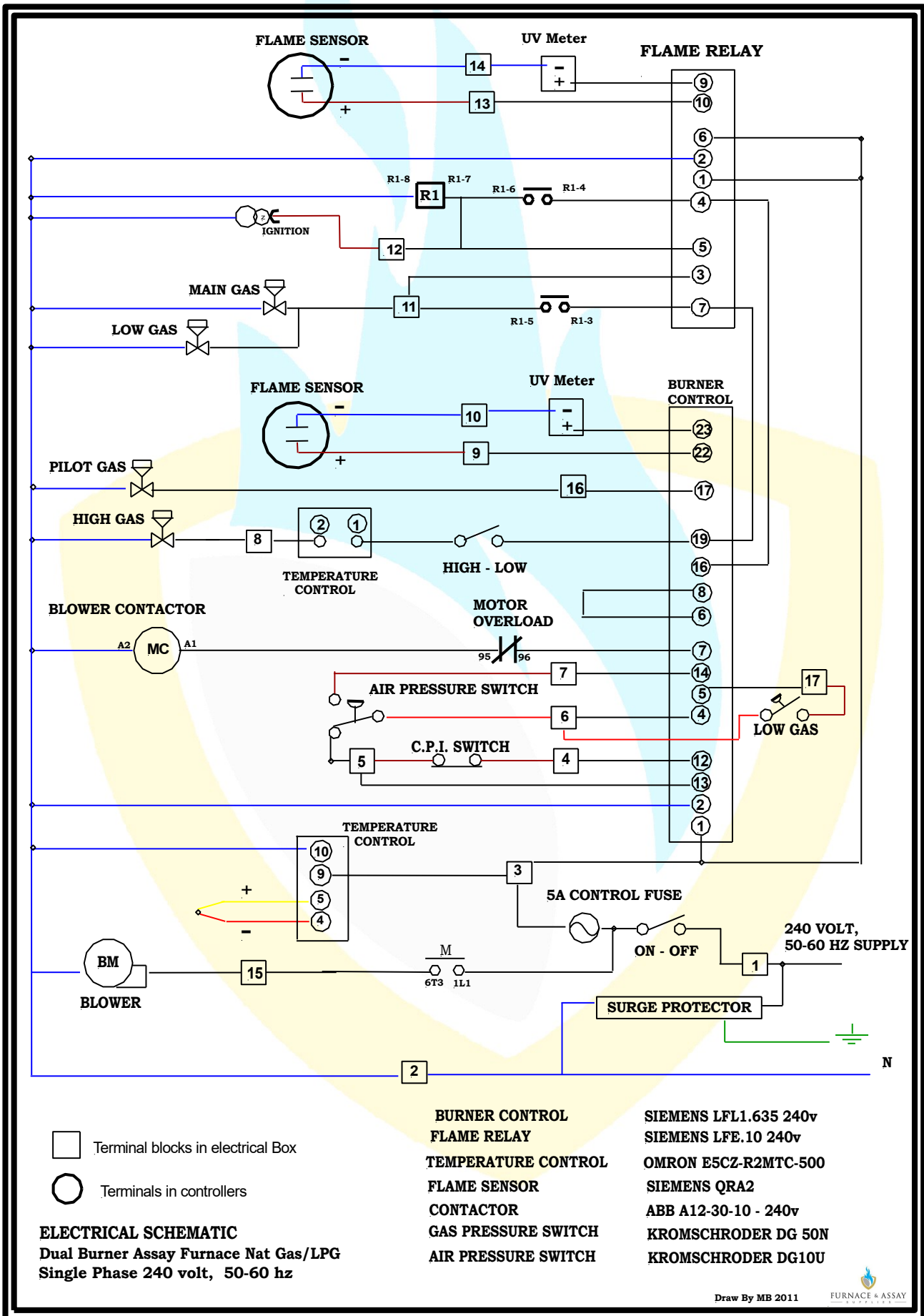

Dual Burner Fan Forced LPG Furnace

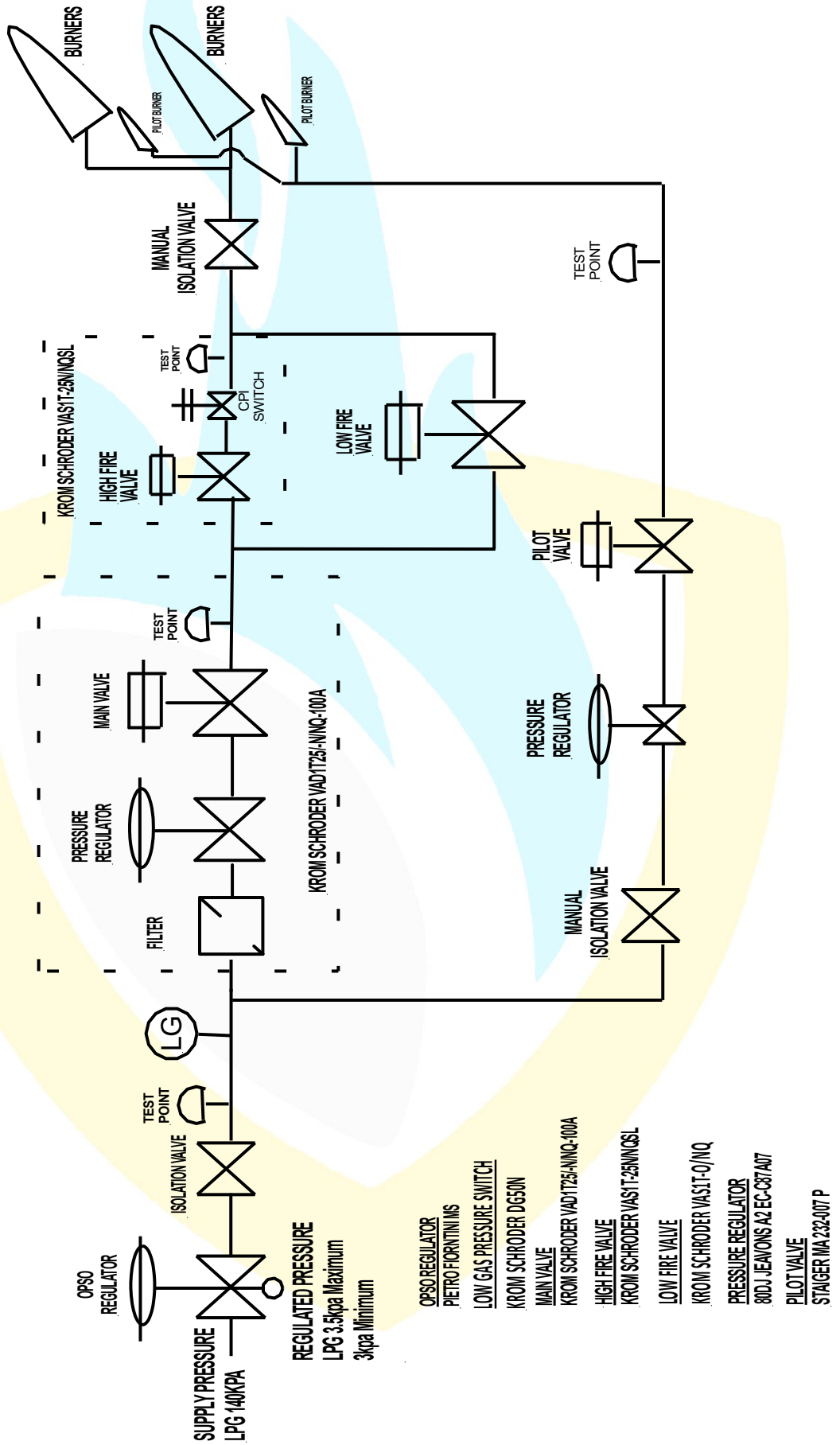

Maintenance

If the furnace has flames coming out of any of these areas below, it is a sign that the furnace desperately needs to be shut down for maintenance.

- from the door while closed

-out of the flues

-the burner port at the back of the furnace.



The furnace should never be left to get to this point. Regular maintenance is essential in the running of all fire assay furnaces.

Maintenance (2)

If the furnace is left to run in this condition, the refractory inside the furnace will be eaten away by the flame, the body and door of the furnace will warp and the burner equipment will become damaged.



Above and Right:
A furnace run with no maintenance for 12 months. Note how the back wall has collapsed in, front bricks are eaten away and there is build up on the walls and roof.



Maintenance (3)

This Flue is almost completely blocked. While standing behind the furnace on ground level this flue looked clear, but as you can see once looking down the flue it is almost completely closed over.

Once a month the furnace must be shut down and maintenance must be performed to keep the furnace running efficiently and economically, and to increase the life span of the furnace.



Keep the inside, rear and top lip of the flues clean and free of debris. If the flues remained blocked it's a sure way of destroying the inside of the furnace. It may also buckle the back of the furnace and damage the Burner equipment.

Maintenance (4)

While the flues remain blocked furnace will need to use additional fuel to maintain temperature.

You will need to ream out the inside of the flues. Make sure it is completely clear from the rim of the flue at the top to the bottom.

The best way to tell is shine a torch down each flue to make sure it is clear.

To ream out a flue, you will need a tool or bar (jimmy/crow bar or a piece of metal), a hammer and a torch.

Using the bar, scrape away the build up from the top all the way to the bottom of the flue, getting as much build up off as possible.

Use the hammer when needed.

Shine the torch down the flue to see if the blockage has been cleared.



This Flue was “cleaned” but the operator failed to check down the flue with a flash.

Only the visible blockages at the top had been removed, yet the flue was still fully blocked.



This is what a flue should look like after cleaning

Maintenance (5)

Keep the inside and rear of the flues clean and free of debris. If the flues remained blocked it's a sure way of destroying the inside of your furnace and you may also buckle the back of the furnace. While the flues remain blocked furnace will need to use additional fuel to maintain temperature.

In the picture to the right the base of the flue is blocked by the chippings from the inside of the flue. This will also have built up around the opening and the inside of the flue. This must be cleared away.



Clean out any loose chippings, build up, broken pots and so on.

Using a Hammer/Jimmy bar/crow bar etc. chip out any build up in this area, until clean and clear.



Maintenance (6)

Keep area at back clean and free of debris.

If there are any spills or broken pots, pull them out the front of the furnace while firing, instead of pushing them to the back.

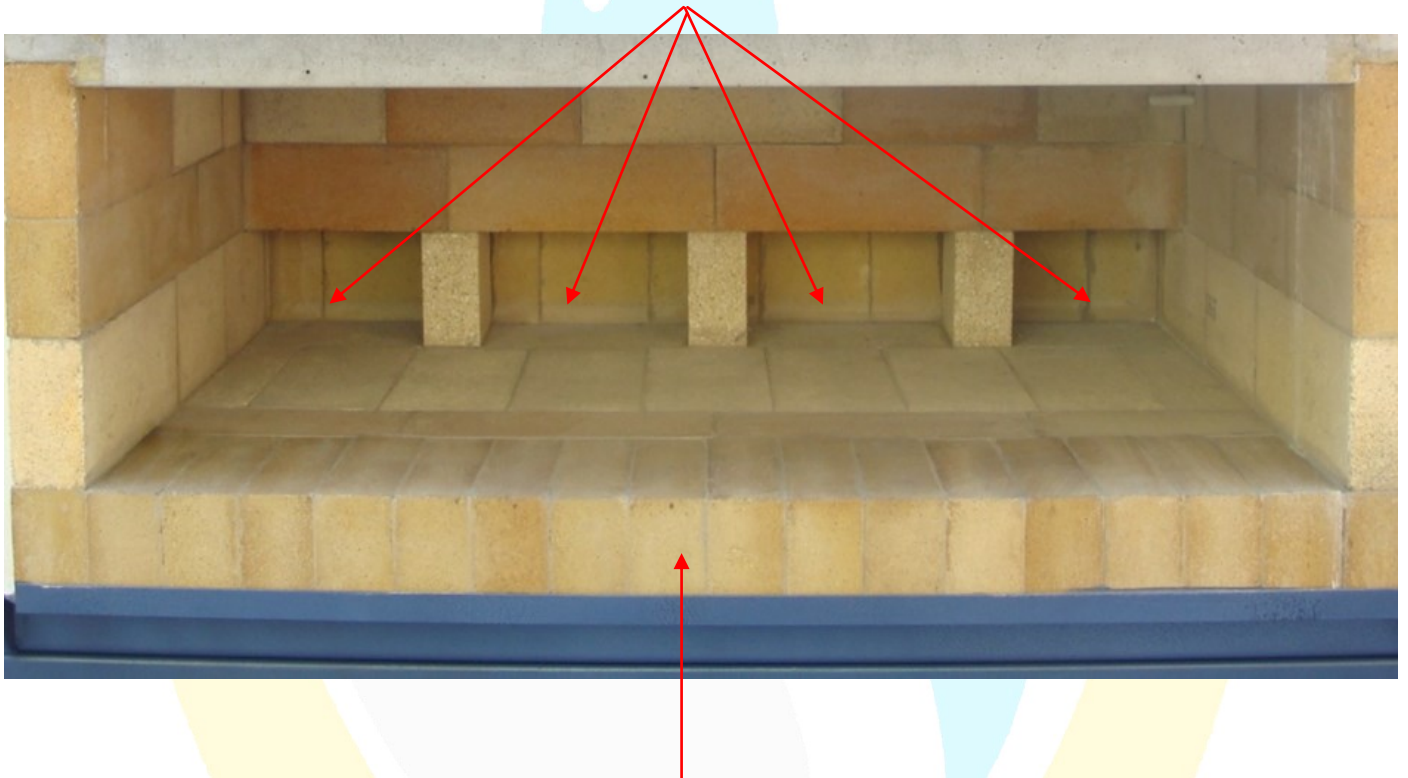

Knock off any Build up/spills that are on the front bricks.
If this is left it will destroy your Door Blanket.



Maintenance (7)

Keep the floor areas around the furnace clean and free of dirt as it will eventually make its way into the blower motor or Inspirator and reduce air flow.

Keep all the burner equipment clean and free of dirt so that the equipment does not over heat.

Schedule regular pressure readings to develop a history of furnace operation.

It is a good idea to dedicate a log book for this purpose. Important readings to monitor are the air pressure, Low fire gas pressure and high fire pressure and UV amp meter readings.

Once you have a history you can then isolate any problems that may arise and reduce downtime because of this.

Maintain Door ceramic blanket. If in poor condition then change.

Refractory Roof Cracking

Over time a furnace roof will develop small and large cracks.

Cracking can happen for many reasons.

The main reason is due to thermal shock when starting up the furnace.

The furnace needs to be taken to temperature slowly to prevent this

(See Warm up Procedure on Page 10).

If a furnace is turned on from cold and taken directly to working temperature cracks will form and issues will arise. Cracks can also happen if a furnace's door is left open after shut down, and the refractory is cooled too quickly.

Once these cracks develop it is essential to fill them with refractory mortar. If cracks are left unfilled you may have issues such as these.



If left they will become larger as impurities will build up in them forcing the cracks wider and decreasing the life of the furnace significantly.



50 PFF Door Re-packing

Changing Face Blanket on Door

If the Face Blanket becomes torn or damaged it must be replaced.

Firstly remove the door (You will need 2 people.)
Pull the four R clips out from hinges (no order needed)

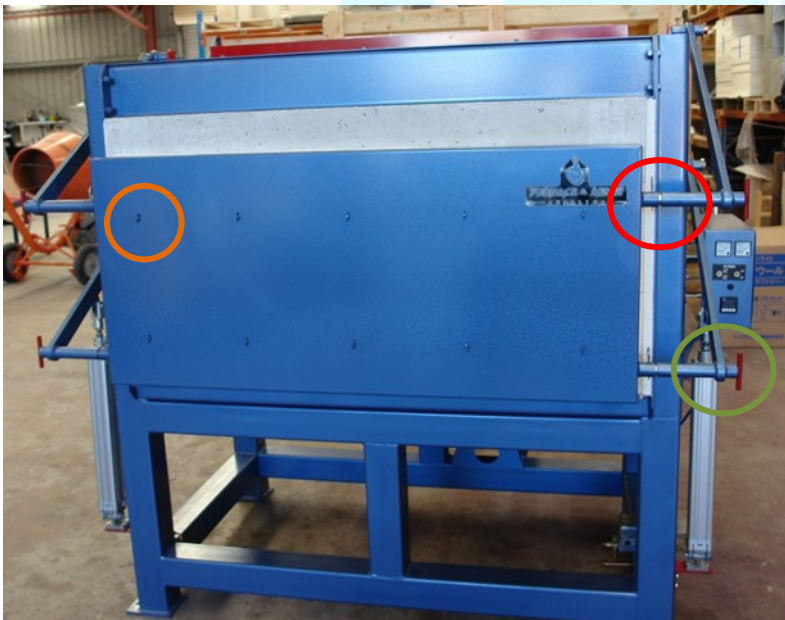

Remove Red handled pins from hinges.
Bottom two first (one person ether side) then top two. Door will then be free to place on a work bench.

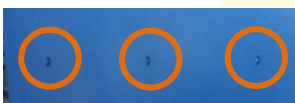
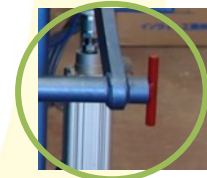

Undo all wing nuts holding anchors in place.

Once wing nuts are undone (do not lose) you will be able to flip to door kaowool side up and remove the ceramic anchors themselves. Be careful not to break these as they can be reused.

Peel off the fist layer of blanket and dispose of.

Cut 25mm Kaowool to the length of the door plus 40mm (width = roll width) and place so that a 20mm overhang of kaowool is present on the edges.

50 PFF Door Re-packing (2)

Using a guide like a screw driver, push up through the existing anchor holes in the door's body, keeping the guide straight until it comes through top layer of kaowool. Once guide is through wiggle around to make a slightly bigger hole.

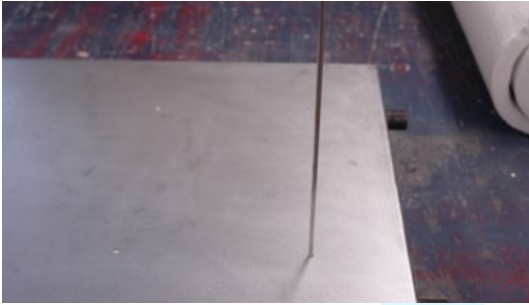

Place a screwdriver through the hole (kaowool side up) then the cutter over the screwdriver (a piece of pipe with a circumference of about 25mm by 100mm long with a mark about 50mm up). Keeping the cutter at 90 deg, cut down to marked line in cutter (50mm) and pull out. Knock out kaowool stuck in cutter.



Once cutter is pulled out there is a hole big enough to place anchor through.



50 PFF Door Re-packing (3)

6. Screw anchors into holes cut out by cutter in kaowool until the bolts come through the pre drilled anchor holes in the door's body. Once bolt is through secure with a wing nut.



7. Once all anchors have been installed, use a straight edged, flat piece of wood and a sharp knife to cut off overhanging kaowool. Make sure the straight edge is lined up flush with the outer lip of furnace door top and bottom. Push straight edge down firmly and cut off excess kaowool.



Replacing Thermocouple Parts

PART NUMBERS FOR COMPONENTS: Thermocouple Type K- FAS 605:

Thermocouple head – FAS-609: Adaptor –FAS 610: Thermocouple Sheath S/S – FAS 673:



Note: FAS-610 and FAS-673 can be purchased together, part number FAS-673A, to save on costs

REMOVE OLD THERMOCOUPLE SHEATH AND INSPECT THERMOCOUPLE. IF OK PROCEED TO SHEATH INSTALLATION

IF NOT THEN REMOVE OLD THERMOCOUPLE AND REPLACE WITH NEW .

MAKE SURE THAT RED MARKED WIRE IS NEG.

If you are Unable to unscrew the thermocouple head
Try unscrewing this screw first, this is a lock screw.



Insert Thermocouple into tc head, and
side sheath over thermocouple.



Once sheath is in position lock into place with grub screw



Make sure the screws in thermocouple
head are tight, and are in correct position.



RED WIRE IS NEG - . YELLOW WIRE IS +

Contact Details



FURNACE & ASSAY

— S U P P L I E S —

Unit 5, 4 Dickens Place

Armadale, 6112

Western Australia, Australia

Phone

+61 8 9399 9299

Fax

+61 8 9399 9288

Email

Info@fandasupplies.com

Web

www.fandasupplies.com